

IT'S NOT JUST SOLAR IT'S SOLAHART

Solar Hot Water Systems



 **Solahart**[®]
HOT WATER *Free* FROM THE SUN[®]





WHY SOLAR HOT WATER MAKES SENSE

THE BIGGEST HOUSEHOLD ENERGY SAVING

Hot water is one of the greatest energy drains on your house. A solar water heater could help you save up to 50% to 90%# of your hot water energy use.

THE MOST EFFICIENT SOLAR ENERGY SYSTEM

A Solahart Solar Hot Water system is proven to be more energy efficient than solar power. It uses the heat from the sun to provide cost-effective and reliable hot water.

THE ORIGINAL, AFFORDABLE SOLAR BATTERY

A solar hot water system works just like a battery, storing energy in the form of hot water, ready for use at a later time. It is the original solar energy storage device, and Solahart has been perfecting it for over 60 years.

LESS ROOF SPACE, MORE SAVINGS

To save the equivalent in energy use, a solar water heater takes up a third of the roof space of a standard solar power system^.

SIMPLICITY OR STYLE

Solahart lets you choose between efficient roof-mounted tanks or slimline split-systems, to minimise visual impact.

#Water Heater energy savings shown are based on Australian Government approved TRNSYS simulation modelling using a medium load, unless otherwise noted. Savings will vary depending upon your location, type of Solahart system installed, orientation and inclination of the solar collectors, type of water heater being replaced, hot water consumption and fuel tariff. Maximum financial savings off your hot water bill are achievable when replacing an electric water heater on a continuous tariff. ^Calculation based on comparing the STCs for a 302L to a 2Kw PV system in zone 3, adjusted for a 10 year deemed period.



6 REASONS

WHY YOU SHOULD INSIST ON
SOLAHART

01 AN UNRIVALLED COMMITMENT TO QUALITY AND TESTING

With over one million systems sold worldwide, Solahart Solar Water Heaters have established an unparalleled reputation for quality and efficiency. All our solar hot water systems are designed and manufactured for the harshest Australian weather conditions. With an enviable Research & Development team working across our manufacturing locations, each generation of solar products we offer will be fundamentally better than the last and will continue to meet our stringent standards of quality and performance.

04 GREATER EFFICIENCY & PERFORMANCE FOR GREATER SAVINGS

With gas and electricity prices going through the roof, it's a great time to farewell your inefficient gas or electric water heater and switch to Solahart Solar Hot Water. Because of their superior efficiency and performance, you could save up to 50% to 90%# of your water heating energy consumption. And because our systems use a range of proven technologies, you are sure to find an efficient and cost effective solar water heating solution, no matter where you live.

02 AUSTRALIA'S FREE ENERGY EXPERTS FOR OVER 60 YEARS

Since 1953, Solahart has been a trusted name in Australian solar, offering the right up-front advice, a problem-free installation, and comprehensive after-sales service. We always start with a free on-site solar assessment and use our Solahart Savings Calculator to show you the savings you could make. Our systems are only available through authorised Solahart dealers and our professional installers are fully trained to Solahart's exacting standards. And most importantly, we offer solar hot water, solar power, and battery storage.

05 TRUSTED SOLAHART WARRANTIES

With over 60 years in solar, we are here for the long haul. Through our Australia-wide dealer network, we will repair or replace components subject to the terms of your warranty. In addition, we will happily provide preventative maintenance and advice on the operation of your system. In the unlikely event of a problem, our team of Solahart dealers will be there to fix it! Your peace of mind is our priority.

03 CREATE A MORE SUSTAINABLE LIFESTYLE

By switching to solar, you'll be making a big difference to your household budget and doing your bit for the planet. With electric water heating accounting for around 25% of the average home's energy consumption and household emissions¹, switching to a Solahart Solar Hot Water system and getting your hot water free from the sun, may help you save up to 3 tonnes of carbon emissions every year.

06 INTEREST FREE FINANCE

Switching to solar has never been more affordable, thanks to our flexible Interest-Free Finance solutions. We offer a wide range of options to suit your needs, and you can apply online to get a response in minutes. Visit our website to see our latest Interest-Free Finance offers, and full terms and conditions.

¹Source: <http://www.energyrating.gov.au/document/report-zoned-map-solar-water-heaters> #Water Heater energy savings shown are based on Australian Government approved TRNSYS simulation modeling using a medium load, unless otherwise noted. Savings and incentives will vary depending upon your location, type of Solahart system installed, orientation and inclination of the solar collectors, type of water heater being replaced, hot water consumption and fuel tariff. Maximum financial savings off your hot water bill are achievable when replacing an electric water heater on continuous tariff.

HOW YOU SAVE

Water heating is the second largest household energy user comprising approximately 25% of the average Australian household's energy use¹. So it makes sense to install a solar water heater to reduce your hot water energy use by up to 50% to 90%[#].

The great thing about solar water heaters is that they store energy free from the sun in a tank, in the form of hot water, ready for use at a later time, which is in effect, just like a battery. And because they are so efficient, solar water heater collectors take up about $\frac{1}{3}$ [^] of the roof space needed for a PV system that would produce an equivalent amount of energy.

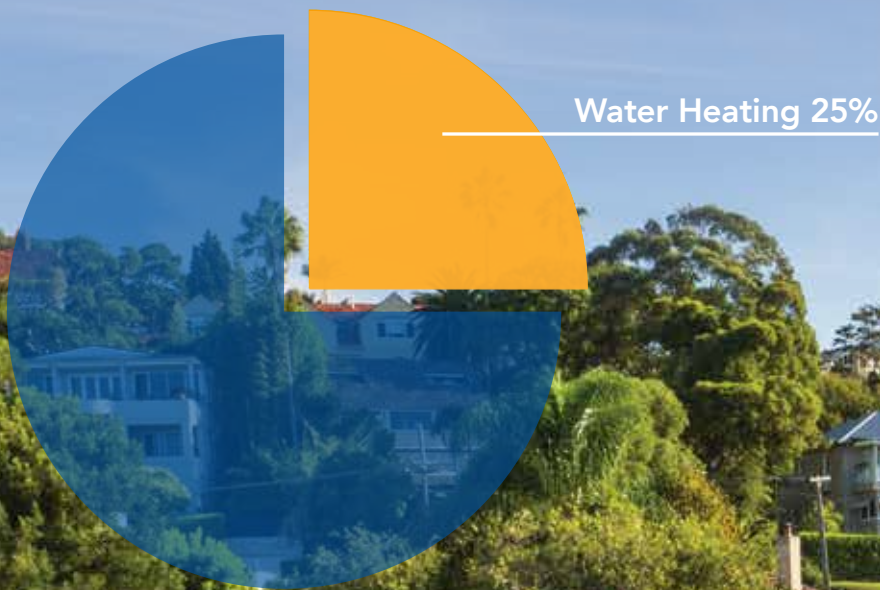

Australian Household Energy Use



¹Source: <http://www.energyrating.gov.au/document/report-zoned-map-solar-water-heaters> [#]Calculation based on comparing the STCs for a 302L to a 2kW PV system in zone 3, adjusted for a 10-year deemed period. ^{*}Water Heater energy savings shown are based on Australian Government approved TRNSYS simulation modeling using a medium load, unless otherwise noted. Savings and incentives will vary depending upon your location, type of Solahart system installed, orientation and inclination of the solar collectors, type of water heater being replaced, hot water consumption and fuel tariff. Maximum financial savings off your hot water bill are achievable when replacing an electric water heater on continuous tariff.

HOW IT WORKS

Solar water heating is a simple and efficient process where energy from the sun is captured to heat water for your home. Collectors installed on your roof use a dark surface to trap the sun's heat and transfer it to the fluid circulating inside. Water is stored in an insulated tank for future use. Every Solahart system also includes a gas or electric booster to ensure you also have hot water even on cold and cloudy days. As world leaders in solar hot water technology, Solahart has developed a range of models to suit every climate zone, roof space, orientation and budget.

- 01** Roof-mounted panels called collectors are heated by the sun.
- 02** Water circulates through the collectors and returns heated to the storage tank that is either located on the roof or on the ground.
- 03** Solar hot water is ready to be used at any time, making it one of the most effective solar energy storage solutions.
- 04** A gas or electric booster ensures you will always have hot water available.

Roof-Mounted Systems

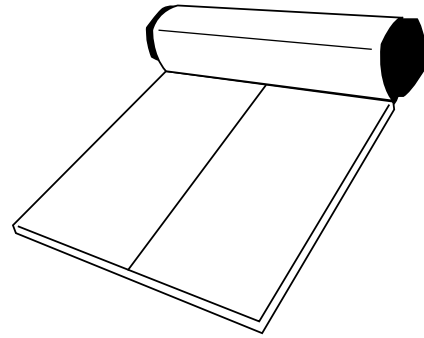

Our Thermosiphon systems have roof-mounted solar collectors closely coupled to a storage tank featuring **Solahart Super-Shield™** enamel protection. These systems are perfect when space at ground level is limited.

Split Systems

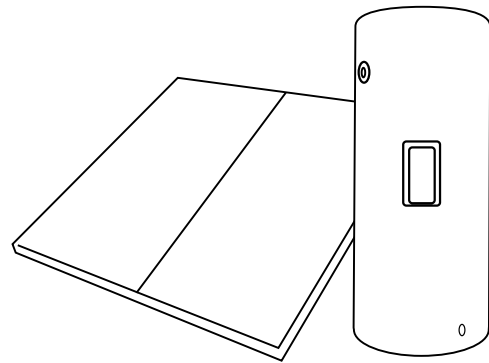

These systems combine roof-mounted solar collectors and a storage tank with Australian-made vitreous enamel protection, that can be installed discreetly on the ground for minimal visual impact.

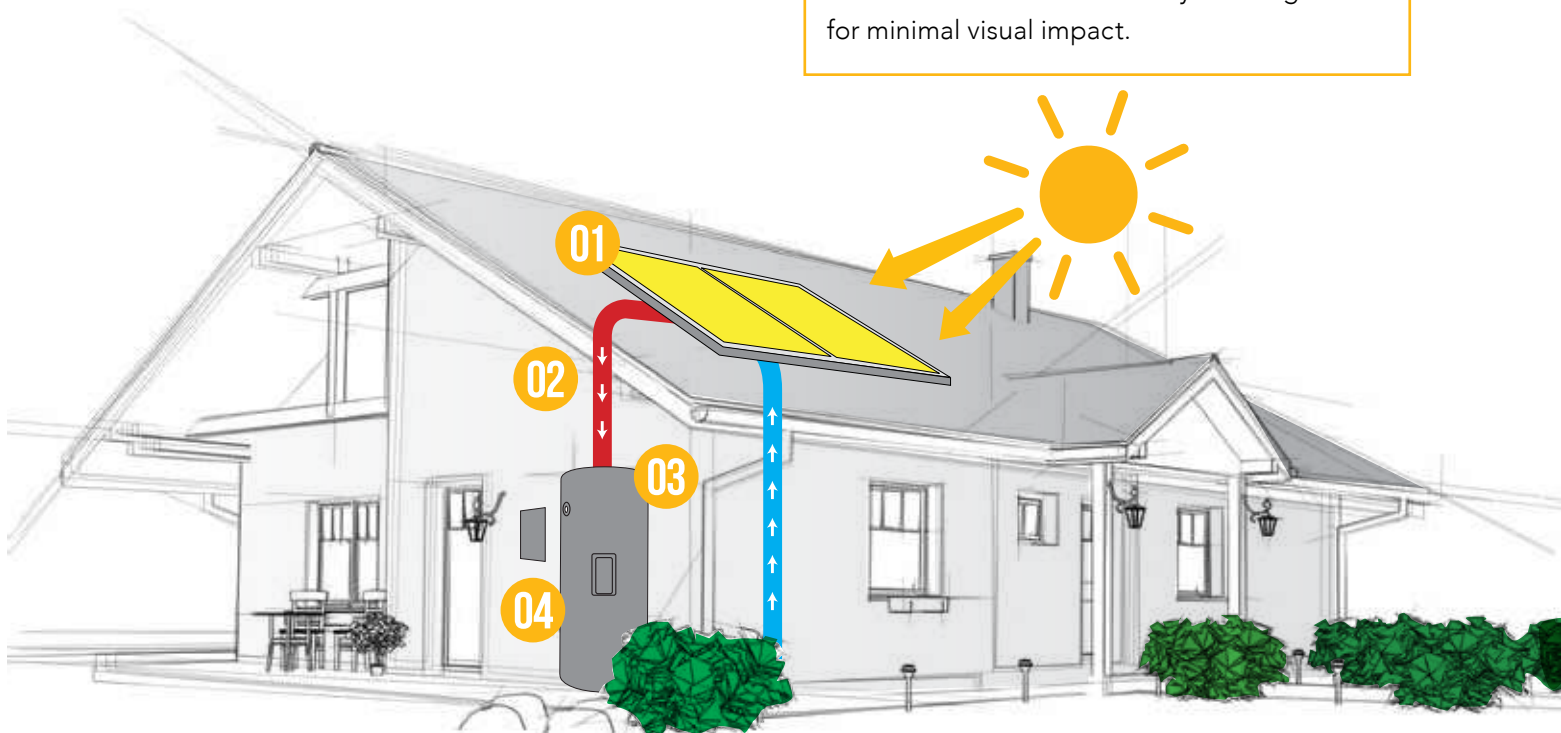

WE WILL HELP YOU CHOOSE THE RIGHT SYSTEM

Investing in solar hot water is a big decision. At Solahart, we always start with a free on-site solar assessment from a trusted Solahart solar expert. We look at all the factors you need to consider then recommend the right system, the correct size, and the perfect configuration for your budget and your needs.

FACTORS WE CONSIDER



Geographical location



Likelihood of frost



Hot water usage



People in your home



Chemistry of your water



Orientation of your roof



Potential shading issues

TAKE ADVANTAGE OF GOVERNMENT INCENTIVES

Solahart Solar Water Heaters are so good for the environment that they qualify for government incentives in the form of Small-scale Technology Certificates (STCs), making it more cost-effective to get into solar hot water. The financial benefit of STCs can significantly reduce the purchase price of your solar water heater.







YOU CAN STILL ENJOY HOT WATER ON CLOUDY DAYS

Australia has the ideal climate for generating **hot water free from the sun**. However, even in the sunniest parts of the country, there are days when cloudy weather can reduce the efficiency of your solar water heater. Fortunately, Solahart has two booster options available to ensure you will not have to settle for lukewarm water when the sun is not shining. Your local Solahart expert can advise you on the booster option that's best for you.



SOLAR ELECTRIC BOOSTERS

Our solar water heaters come with an inbuilt, thermostatically controlled electric booster. As soon as the internal temperature of your tank drops, the booster kicks in and heats the water. The electric booster can be installed with an automatic timer, so you are always in control of your boosting patterns.

Many people choose to set their timer for the afternoon so hot water is ready in the evening.



GAS BOOSTING

With a gas boosted model, boosting only occurs when hot water is being used. When a hot tap is opened, solar hot water flows from the solar water heater through a solar-compatible continuous flow gas water heater. Temperature sensors within this gas heater measure the incoming water temperature, and if the water temperature is less than a pre-set minimum, the gas heater ignites and immediately brings it up to the set level.

A BREATH OF FRESH AIR FOR THE ENVIRONMENT

Imagine a sustainable energy future where you could worry less about growing energy bills, and the future of the planet. Thanks to Solahart Solar Hot Water, that future can begin today.

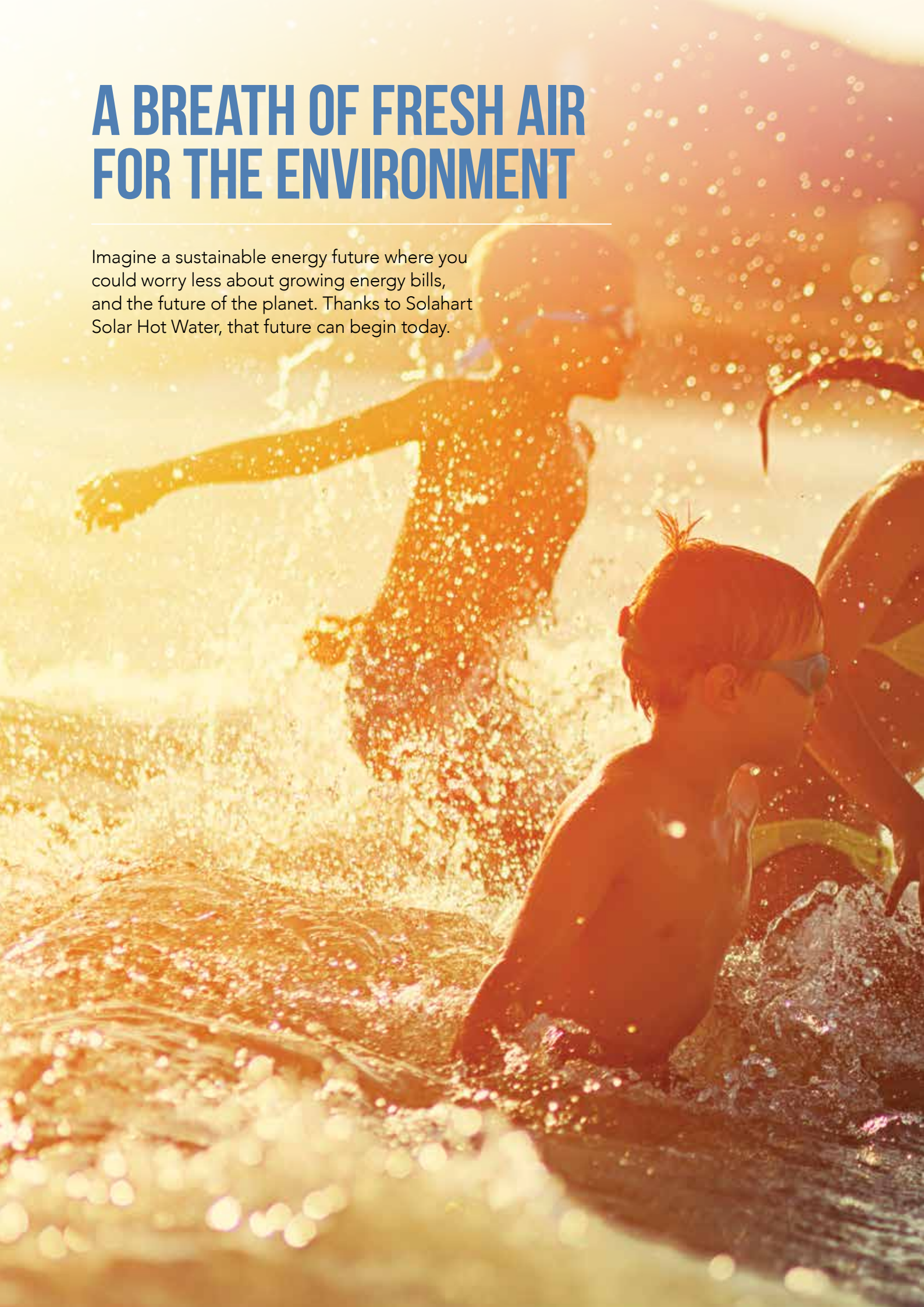



Rid the planet of up to
3 TONNES OF CARBON
every year

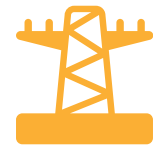

Be less reliant
ON BIG POLLUTING
energy companies



Save the equivalent of
TAKING A MID-SIZED CAR
off the road

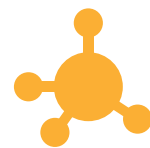

CUT GREENHOUSE GAS EMISSIONS
to do your bit for
the planet



Lead the
RENEWABLES REVOLUTION
in your community

THE SOLAHART SOLAR WATER HEATER RANGE

As world leaders in solar hot water technology, Solahart has developed a range of models to suit every climate zone, roof space, orientation and budget.



ROOF TOP SYSTEMS WITH THE TOUGHEST STORAGE TANK UNDER THE SUN

Our range of Thermosiphon systems feature roof-mounted solar collectors closely coupled to a storage tank, making them a perfect solution for people with limited space at ground level. As the sun heats the water in the solar collectors, the increase in temperature causes it to rise and move into the storage tank where it displaces cooler water back into the solar collectors to be heated again. This process continues while solar energy is available. The elegant simplicity of this system provides efficiency, reliability and low maintenance, as it does not require a pump to circulate water through the system.

KEY FEATURES



Solahart Super-Shield™ enamel tank protection



Trusted Solahart Warranties



Environmental Incentives



Low-maintenance and reliable operation



Gas or Electric booster options available

SPLIT SYSTEMS FOR FLEXIBILITY AND STYLE

Low profile split systems are perfectly suited to modern roof profiles. Solahart split systems combine roof-mounted collectors with a tank that can be installed discreetly on the ground for minimal visual impact. Split systems use an electric pump to circulate water in a continuous cycle from the bottom of the tank and through the solar collectors where it absorbs the heat from the sun before being returned back to the tank.

KEY FEATURES



Trusted Solahart Warranties



Environmental Incentives



Stylish slimline design for minimum visual impact



Two types of solar collectors available



Gas or Electric booster options available



ROOF-MOUNTED THERMOSIPHON

Open Circuit System

Open circuit systems circulate and heat water directly through the collectors. These systems have no frost protection and are not suitable for harsh water regions.*

SOLAHART L SERIES (180 and 300 Litre Models)



300 Litre Model



OPTIMAL PERFORMANCE
Our most popular system, designed for **medium to high** solar gain areas.



ENVIRONMENTAL BENEFITS
Reduced energy use can save up to 1.4 to 2.7 tonnes of CO₂ emissions per annum.#



REDUCES ENERGY USAGE
Water heating energy use for medium load households may be reduced by **50% to 85%.**#

SOLAHART LCSD SERIES (300 Litre Model)



300 Litre Model



HIGH PERFORMANCE
Designed to provide higher efficiency for use in **low to medium** solar gain areas that do not experience frost.



ENVIRONMENTAL BENEFITS
Reduced energy use can save up to 1.5 to 3.1 tonnes of CO₂ emissions per annum.#



OVER TEMPERATURE PROTECTION
Thermosiphon restrictor valve (TRV) fitted as standard.



REDUCES ENERGY USAGE
Water heating energy use for medium load households may be reduced by **55% to 90%.**#

Solahart Warranty Details: 10/5/5 warranty (Free Heat models) – 10 years cylinder and collector supply, 5 years parts, 5 years labour.
5/5/5 warranty (standard) – 5 years cylinder and collector supply, 5 years parts, 5 years labour.

*Water Heater energy savings shown are based on Australian Government approved TRNSYS simulation modeling using a medium load, unless otherwise noted. Savings and incentives will vary depending upon your location, type of Solahart system installed, orientation and inclination of the solar collectors, type of water heater being replaced, hot water consumption and fuel tariff. Maximum financial savings off your hot water bill are achievable when replacing an electric water heater on continuous tariff.

Closed Circuit System

Closed circuit systems circulate an anti-freeze fluid to heat water indirectly via a heat exchanger which makes them suitable for frost or harsh water regions.~ These systems utilise Australian-designed revolutionary Envelope Collector technology.

SOLAHART SP SERIES (180 and 300 Litre Models)



300 Litre Model



OPTIMAL PERFORMANCE

Designed to provide efficient performance in **medium to high** solar gain areas and suitable for frost or harsh water quality areas.



ENVIRONMENTAL BENEFITS

Reduced energy use can save up to 1.4 to 2.9 tonnes of CO₂ emissions per annum.#



FROST RESISTANT

Suitable for frost prone or harsh water chemistry areas.



REDUCES ENERGY USAGE

Water heating energy use for medium load households may be reduced by **50% to 85%**.#

SOLAHART CS SERIES (300 Litre Model)



300 Litre Model



HIGH PERFORMANCE

Designed to provide higher collector performance in **low to medium** solar gain areas and suitable for frost or harsh water quality areas.



ENVIRONMENTAL BENEFITS

Reduced energy use can save up to 1.7 to 3.4 tonnes of CO₂ emissions per annum.#



FROST RESISTANT

Suitable for frost prone or harsh water chemistry areas.



REDUCES ENERGY USAGE

Water heating energy use for medium load households may be reduced by **60% to 90%**.#

Solahart Warranty Details: 10/5/5 warranty (Free Heat models) – 10 years cylinder and collector supply, 5 years parts, 5 years labour.
5/5/5 warranty (standard) – 5 years cylinder and collector supply, 5 years parts, 5 years labour.

SPLIT SYSTEM

Open Circuit System

Open circuit systems circulate and heat water directly through the collectors. Open circuit systems have limited frost protection^a and are not suitable for harsh water regions.[~]

SOLAHART MLV SERIES (270, 320 and 410 Litre Models)



OPTIMAL PERFORMANCE

Suitable for use in **medium to high** solar gain areas, with minimal frost exposure.



ENVIRONMENTAL BENEFITS

Reduced energy use can save up to 1.5 to 3.0 tonnes of CO₂ emissions per annum.[#]



BUILD QUALITY

Toughened, hail resistant collector glass.



REDUCES ENERGY USAGE

Water heating energy use for medium load households may be reduced by **55% to 85%**.[#]

SOLAHART MCSV SERIES (270, 320 and 410 Litre Models)



HIGH PERFORMANCE

Suitable for use in lower solar gain areas with minimal frost exposure.



ENVIRONMENTAL BENEFITS

Reduced energy use can save up to 1.6 to 3.0 tonnes of CO₂ emissions per annum.[#]



ENVELOPE COLLECTORS

Australian designed revolutionary collector technology. Toughened, hail resistant collector glass.



REDUCES ENERGY USAGE

Water heating energy use for medium load households may be reduced by **60% to 90%**.[#]

Solahart Warranty Details: 5/3/2 warranty – 5 year cylinder and collectors supply, 3 year cylinder and collectors labour, 2 years parts labour; applies to a single family domestic dwelling only. All other applications have a 3/1/1 warranty; 3 years cylinder supply, 1 years parts, 1 year labour warranty.

^aWater Heater energy savings shown are based on Australian Government approved TRNSYS simulation modeling using a medium load, unless otherwise noted. Savings will vary depending upon your location, type of Solahart system installed, orientation and inclination of the solar collectors, type of water heater being replaced, hot water consumption and fuel tariff. Maximum financial savings off your hot water bill are achievable when replacing an electric water heater on continuous tariff. ^bLimited Frost Protection – these systems have a level of freeze protection designed to guard against freeze conditions and have a Solahart warranty for freeze damage (Australia only – conditions apply) when the water heater is installed at an altitude not exceeding 400m above sea level.

Closed Circuit System

Closed circuit systems circulate an anti-freeze fluid and heat water indirectly via a heat exchanger. Closed circuit systems are suitable for frost or harsh water regions.~

PREMIER LOLINE SERIES (270 Litre Model)



OPTIMUM PERFORMANCE

Suitable for use in lower to high solar gain areas.



REDUCES ENERGY USAGE

Water heating energy use for medium load households may be reduced by **40% to 80%**.#



FROST RESISTANT

Suitable for frost prone or harsh water chemistry areas.



BOOSTER OPTIONS

Gas or electric boost options available.

Premier Loline Warranty Conditions. Solar tank/collectors – 5 years supply on cylinder and solar collectors, 3 years labour on cylinder, 1 year labour on collector, 1 year supply and labour on other parts.

BOOSTER

Inline System

Inline Gas Booster systems can boost the temperature of your solar system on days where solar gain is limited. Suitable for frost areas but not suitable for harsh water regions.~

INLINE GAS BOOSTER™ (20 and 27 Litre/min Models)



HIGH PERFORMANCE

Suitable for use in lower to high solar gain areas.



REDUCES ENERGY USAGE

Rated 6-Stars for energy efficiency and have no pilot light to minimise energy waste.



NATURAL GAS/ PROPANE OPTIONS

Natural Gas and Propane models available.



ALL SYSTEM COMPATIBILITY

Can be used with Thermosiphon (on roof) or Split Systems.

~Harsh water regions – the Solahart warranty may not apply if the water heater is connected to a water supply which: is scaling with a saturation index >+0.8, or is corrosive with a saturation index <-1.0 or, has a total dissolved solid content <2500mg/L. Any financial savings will vary depending upon type of Rheem Solar system installed, orientation and inclination of the solar collection, type of water heater being replaced, hot water consumption and fuel tariff. Maximum financial savings off your hot water bill are achievable when replacing an electric water heater on continuous tariff. #Solahart inline Gas Boosters are suitable for outdoor installation only.



DON'T TRUST ANYTHING LESS THAN SOLAHART



EXPERT ADVICE

A free on-site solar assessment, quality installation and superior after-sales service from Australia's free energy experts



1 MILLION +

Australia's trusted name in solar with over one million systems installed worldwide since 1953



UNRIVALLED QUALITY

Our systems are designed and manufactured for the harshest Australian conditions



RIGOROUS TESTING

Our systems are rigorously tested to ensure optimum performance and quality.

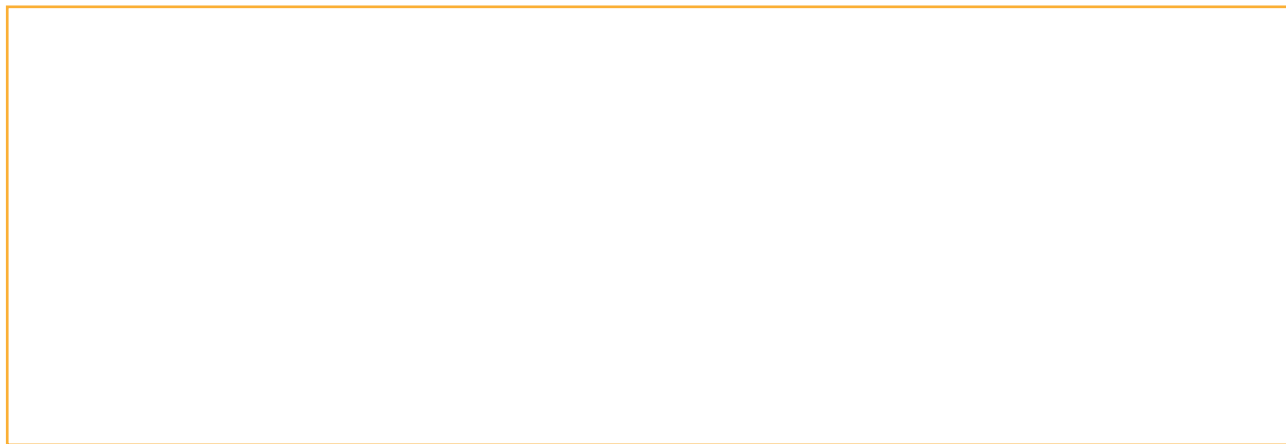

Do you have any questions about Solahart products? If so, don't hesitate to contact us.

Call **1300 769 475**
or visit **solahart.com.au**

 **Solahart**[®]
HOT WATER *Free* FROM THE SUN[®]